

PILE UP

PRINTING INSTRUCTIONS PER PARTICIPANT:

- 1 plain paper copy each page**
- 1 2 sided copy of pages 2 & 3 on card stock
weight prefer shade of green if possible**
- 1 copy of page 4 on white card stock**

*keep for
masters*

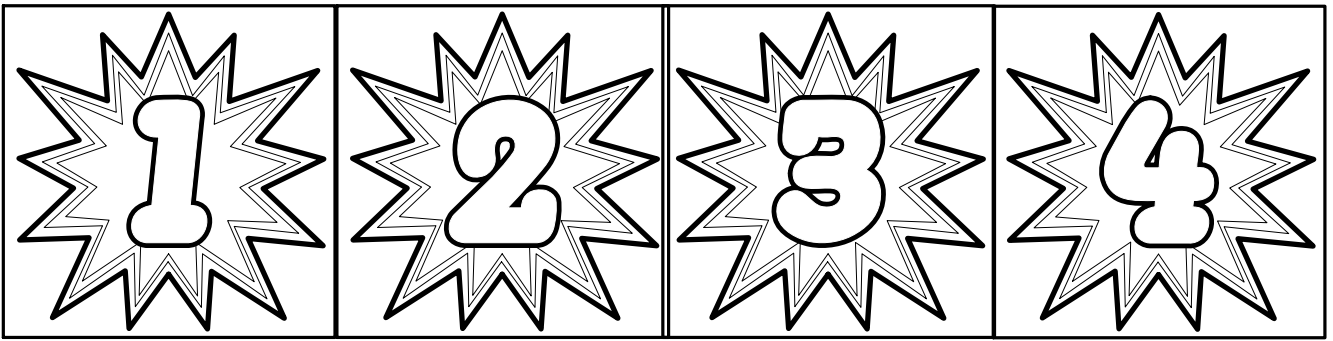

Pile Up Reading

PREPARATIONS:

Write various vocabulary words on craft sticks. (See list) Color point chart the 4 different colors of the sticks in play. Add colored point dots to sticks if using plain wooden sticks. Place in container. Add a die.

GAME:

Drop all sticks randomly on floor/table. First student rolls die. A roll of 3 on die, student has 3 chances to successfully remove a stick. (Variation, student may attempt to pick up 3 sticks) Once a student has removed a stick they must read the word. Next they sort the word into the correct category on their pile up place mat; either PBJ or L-C. If the student is using the barrel side of the mat they must sort the word into the correct barrel and if possible explain their choice by using the word correctly.

Play moves to next student.

After all sticks have been picked up from the pile, all players add up their individual points based on the point value chart. This gives them their TOTAL SCORE for the game. By using the point value chart method, the winner is not necessarily determined by the player with the most sticks.

OPTIONS: Increase the point values as students become more proficient in Simple Math or hide the point values until the game is over and reveal them at that point.

HINT: Make sure the various vowel patterns are not all written on the same color of stick. I like to give my students the sticks to sort for an independent activity and all the "oa" words are on yellow sticks, then they don't have to read the words they just sort them by colors. Small pencil boxes make great game container.

Pile Up Reading

*color
and cut
for game*

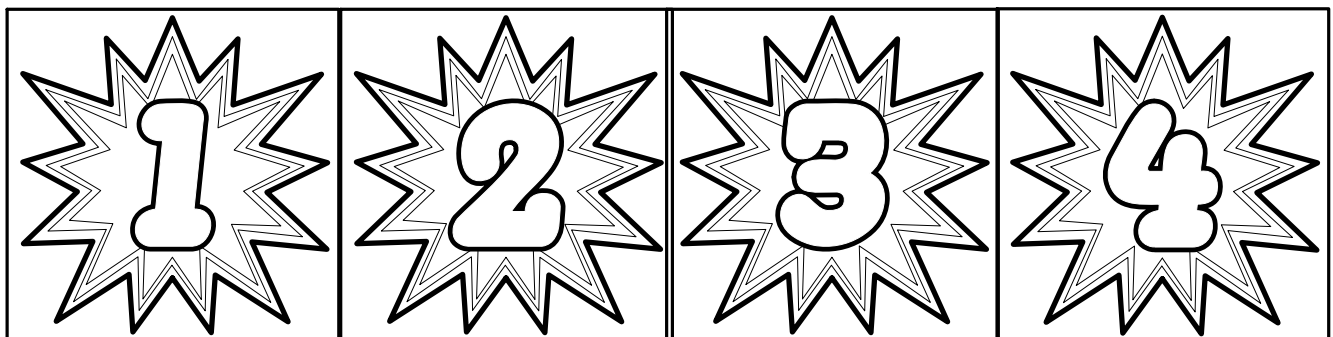

Color point values different colors to match stick colors and laminate and color box lid title any color desired.

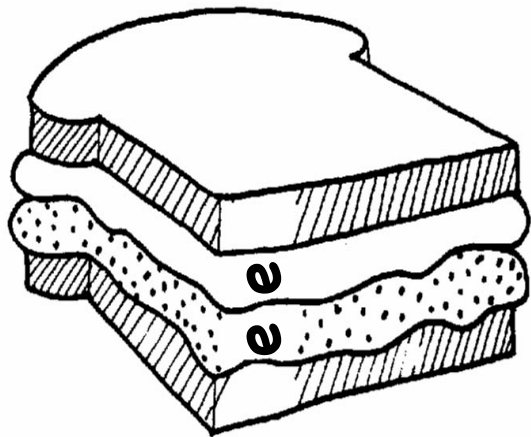
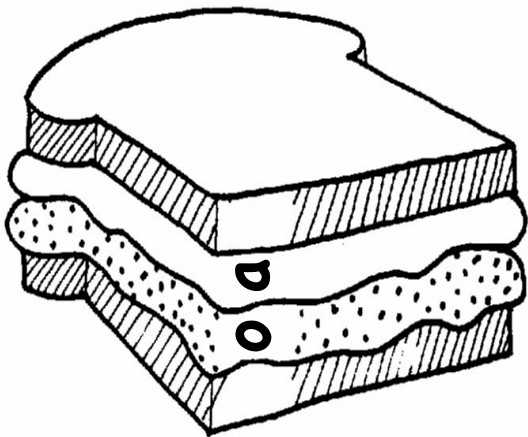
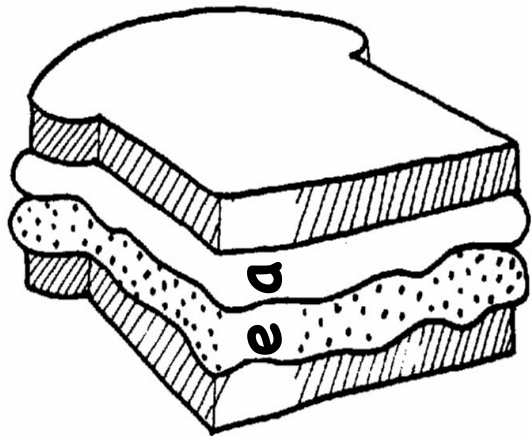
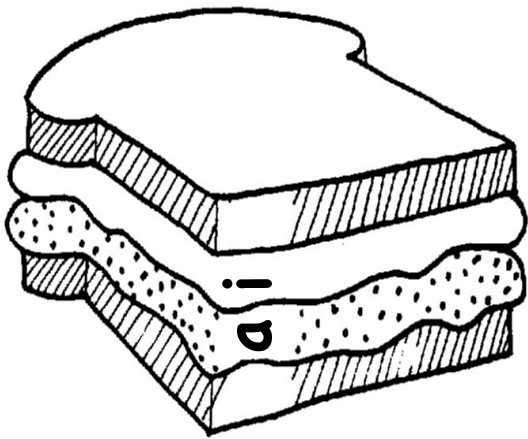

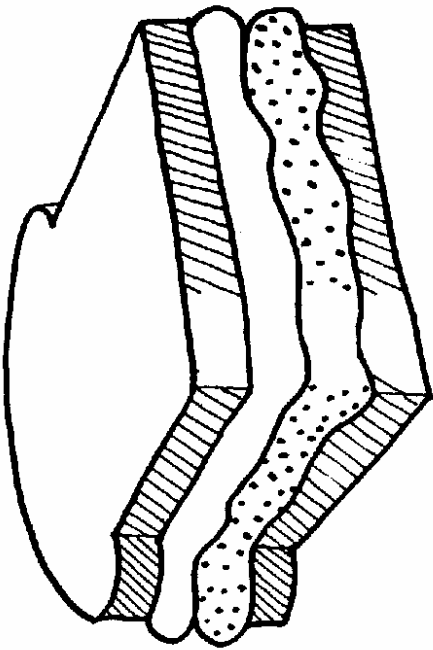
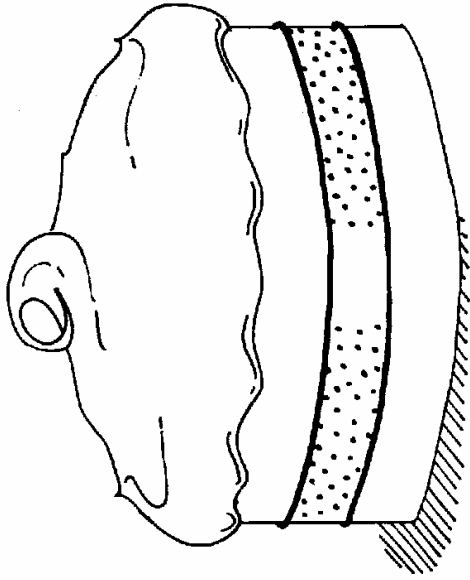

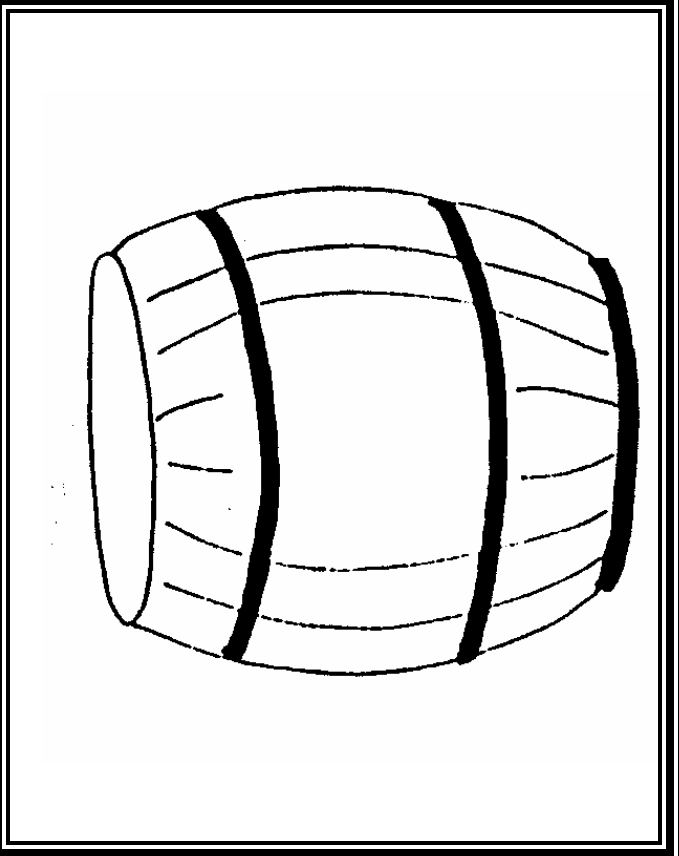
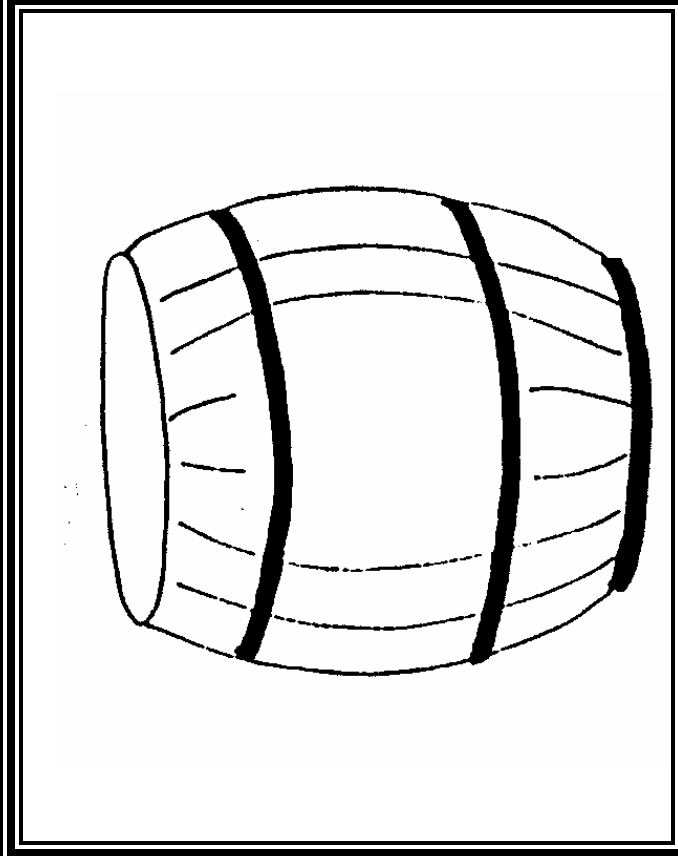
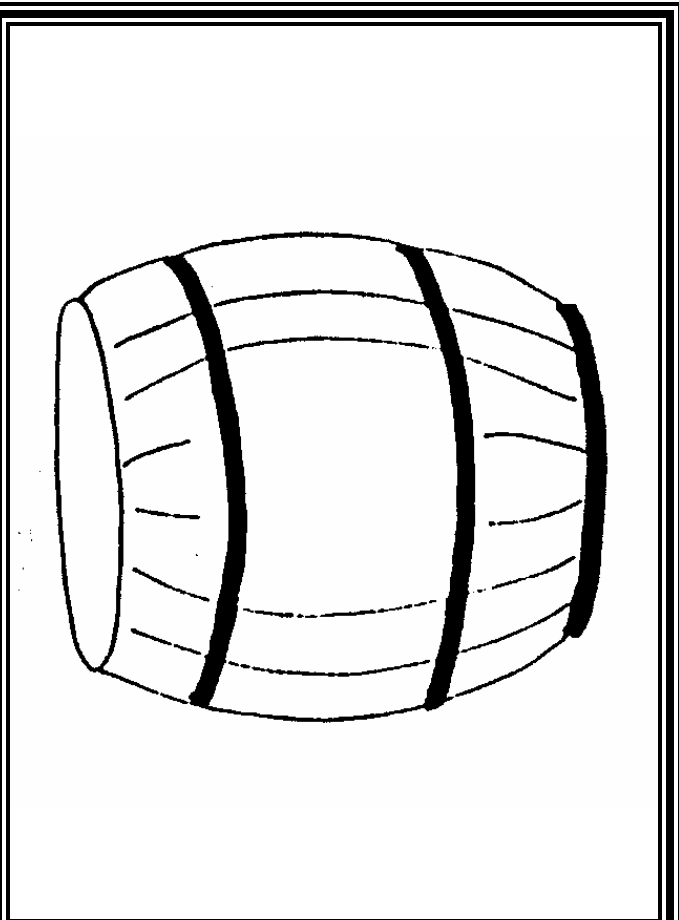
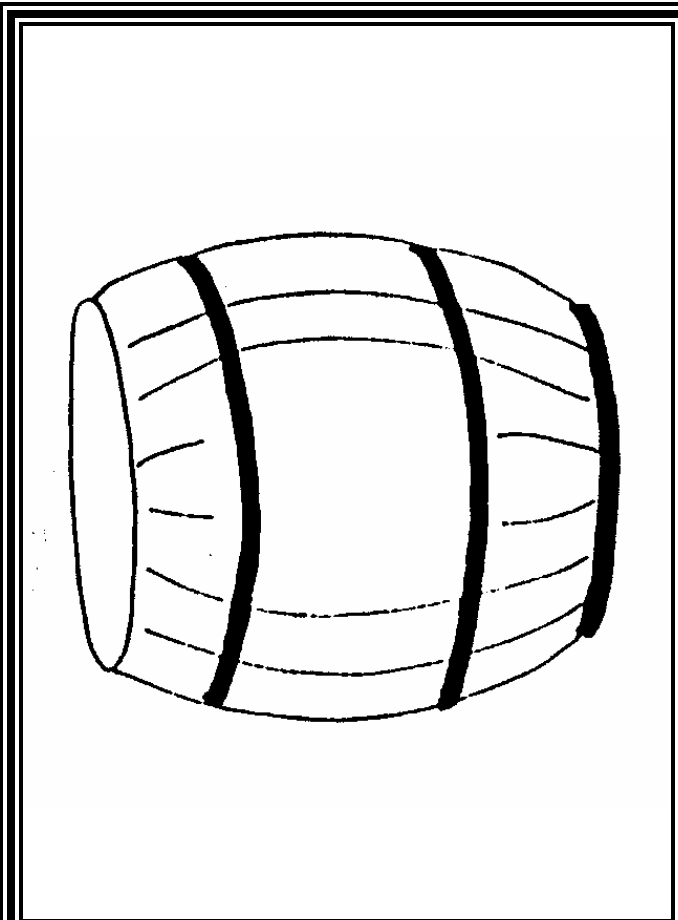

"Pile Up Mat" Designed by Nancy Ziehme, QueSSI Consulting, 2001

Pile Up Mat Directions:

Copy the masters onto one piece of card stock making it into a two sided page. Make one mat for each student. Laminate.

Usage Suggestions:

To use with "Pile Up" give each player a mat. Player places the mat directly in front of them. They may decide which side to display or the teacher may assign which side will be face up depending on the student's level. After the student has a turn to pick up a stick and read the word, the student then sorts the stick by placing in appropriate category on their mat. This gives the student the opportunity to focus on another aspect of the word they just read.

Other uses may include:

- Independent activity for the student to sort words from the card games.
- Two students can share one mat and draw vocabulary cards from a draw pile and sort them onto the appropriate category.
- Play "Thumbs Up" by having the mat out on each student's desk while doing auditory discrimination activities from the Stevenson Spelling Manuals.
- Use dry erase markers to "Tally Mark" how many PBJ or L-C words they find in a library book.

Be creative to find additional uses for the laminated mat.

Green Beginning Level Word Suggestions

SET ONE must complete Integral 39

| oa words | | ai words | | ee words | | ea words | | ai = ay | |
|----------|------|----------|------|----------|-------|----------|------|---------|-----|
| foam | loaf | wait | maid | beef | peel | bead | team | bay | hay |
| coat | foal | tail | hair | beet | peep | beam | peak | lay | say |
| boat | coal | sail | fail | feet | meeek | beak | leak | may | way |
| toad | loan | rain | bait | heel | seek | fear | read | day | ray |
| foal | goat | raid | bail | jeep | week | gear | mean | nay | Kay |
| roam | road | pair | fair | meet | keel | heat | seal | pay | Jay |
| soap | moan | jail | | weep | weed | leaf | year | Fay | |
| soak | | | | keep | | | hear | bay | hay |

SET TWO must complete Integral 54

| a - e | | o - e | | i - e | | open sandwich | |
|-------|------|-------|------|-------|------|---------------|-----|
| bake | pale | bone | lone | bike | mile | eel | oak |
| cake | late | code | mole | dime | nine | bee | tee |
| base | maze | cone | nose | fine | pipe | sea | tea |
| date | name | dome | rope | hide | ride | eel | oar |
| fame | rake | hope | sore | kite | size | aim | ear |
| haze | save | hole | tore | life | tide | aid | eat |
| game | vase | joke | | vine | | air | see |

SET THREE Blends with PBJ/L-C through Integral 95

| | | | | | | | | |
|-------|-------|-------|-------|--------|--------|--------|-------|--------|
| croak | toast | slope | close | trail | bleed | breed | bleat | plead |
| float | roast | smoke | drain | claim | fleet | speed | bleak | leave |
| gloat | broke | snore | plain | stair | sleek | greed | dream | crease |
| groan | drove | spoke | stain | praise | tree | green | flea | grease |
| bloat | froze | stole | snail | grain | freeze | greet | freak | please |
| boast | grove | stone | brain | braid | fleece | breeze | gleam | tease |
| coast | clove | store | train | | | sneeze | pleat | clean |

Sample of Craft Stick

load

jeep

- 🌈 Sticks may have combinations of up to 4 words per stick from each set above by using both ends and the front/back of each craft stick. Dependent learners may need the same word on each side.
- 🌈 By using the three sets of words, three different "Pile Up" games will be created. This provides flexibility when various groups are in class at the same time.
- 🌈 Be sure to store the sets in clearly labeled bags or containers to grab the correct words for each group. Select vocabulary most appropriate for your students.
- 🌈 Add additional sets as students make progress in the program; Lonely Vowels, Bully 'R', Piggy Words...